

BLDC-Motor Typ BL57S



Technische Daten

Modell	BL57.58S	BL57.78S	BL57.98S
Nennspannung (V)	48	48	48
Nennzahl (min ⁻¹)	3000	3000	3000
Nennmoment (Ncm)	20	40	60
Nennleistung (W)	63	125	188
Nennstrom (A)	1.6	3.3	5.0
Spitzenstrom (A)	4.8	9.9	15.0
Spitzendrehmoment (Ncm)	60	120	180
Rotorträgheitsmoment (gcm ²)	420	630	910
Drehmomentkonstante (Ncm/A)	12.5	12.1	12.0
Gegen-EMK (V/min ⁻¹)	13.08	12.71	12.56
Widerstand (Ω)	1.11	0.93	0.52
Induktanz (mH)	0.91	0.65	0.43
Länge (mm)	58	78	98
Gewicht (kg)	1.0	1.4	1.8
Pole	8		
Phasen	3		
Isolierklasse	B		

Rel. Luftfeuchtigkeit: 20 bis 85% | Umgebungstemp.: -20 bis +50 °C

Anschlüsse

UL1007 AWG26	
Rot	Vcc
Gelb	Ha
Grün	Hb
Blau	Hc
Schwarz	GND

UL3266 AWG22	
Gelb	U
Grün	V
Blau	W

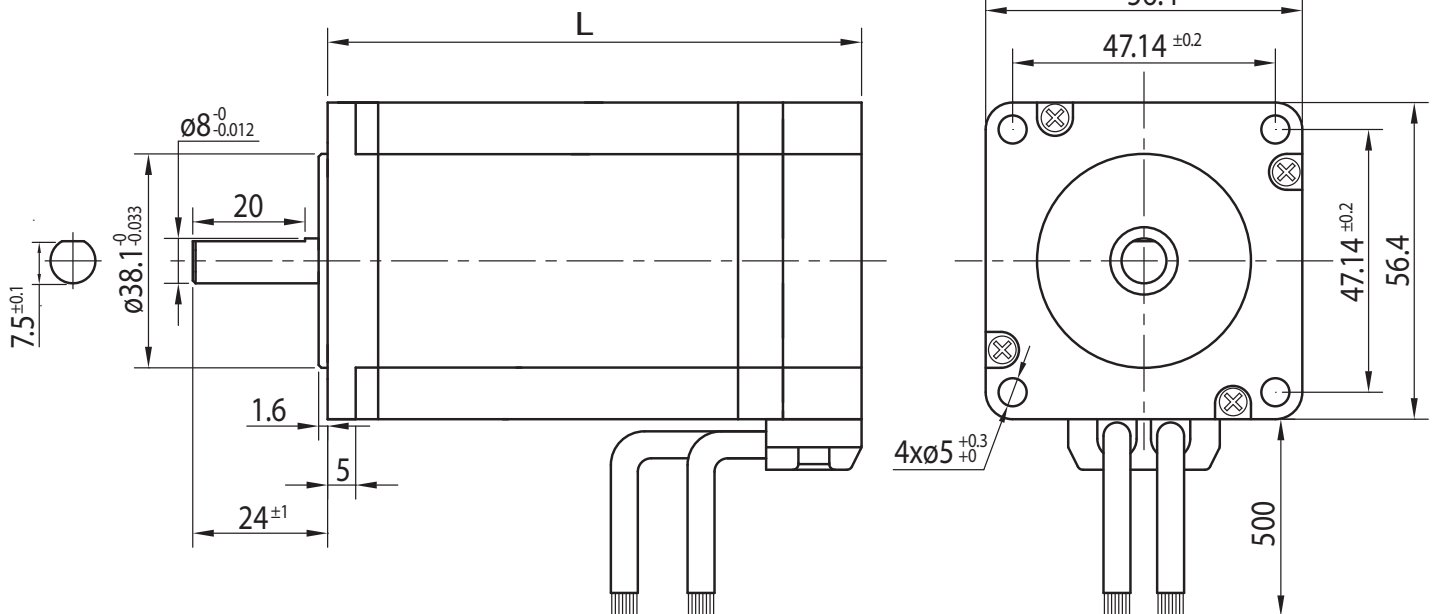
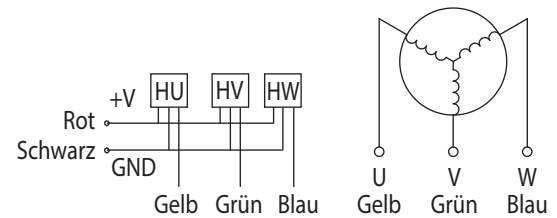

Optionen

Encoder	Sonderwelle
B-seitige Welle	Sonderspannung
Anschlusstecker	Isolierklasse F/H