

# BLDC-Motor Typ BL61S



## Technische Daten

Modell	BL61.66S	BL61.87S	BL61.108S
Nennspannung (V)	48	48	48
Nennzahl (min <sup>-1</sup> )	3000	3000	3000
Nennmoment (Ncm)	25	50	75
Nennleistung (W)	78	156	234
Nennstrom (A)	2.2	4.4	6.6
Spitzenstrom (A)	6.6	13.2	19.8
Spitzendrehmoment (Ncm)	75	150	225
Rotorträgheitsmoment (gcm <sup>2</sup> )	500	900	1300
Drehmomentkonstante (Ncm/A)	11	11	11
Gegen-EMK (V/min <sup>-1</sup> )	10.5	10.5	10.5
Widerstand (Ω)	1.5	0.6	0.5
Induktanz (mH)	1.3	0.65	0.4
Länge (mm)	66	87	108
Gewicht (kg)	0.9	1.25	1.6
Pole	8		
Phasen	3		
Isolierklasse	B		

Rel. Luftfeuchtigkeit: 20 bis 85% | Umgebungstemp.: -20 bis +50 °C

## Anschlüsse

UL1007 AWG26	
Rot	Vcc
Gelb	Ha
Grün	Hb
Blau	Hc
Schwarz	GND

UL3266 AWG22	
Gelb	U
Grün	V
Blau	W

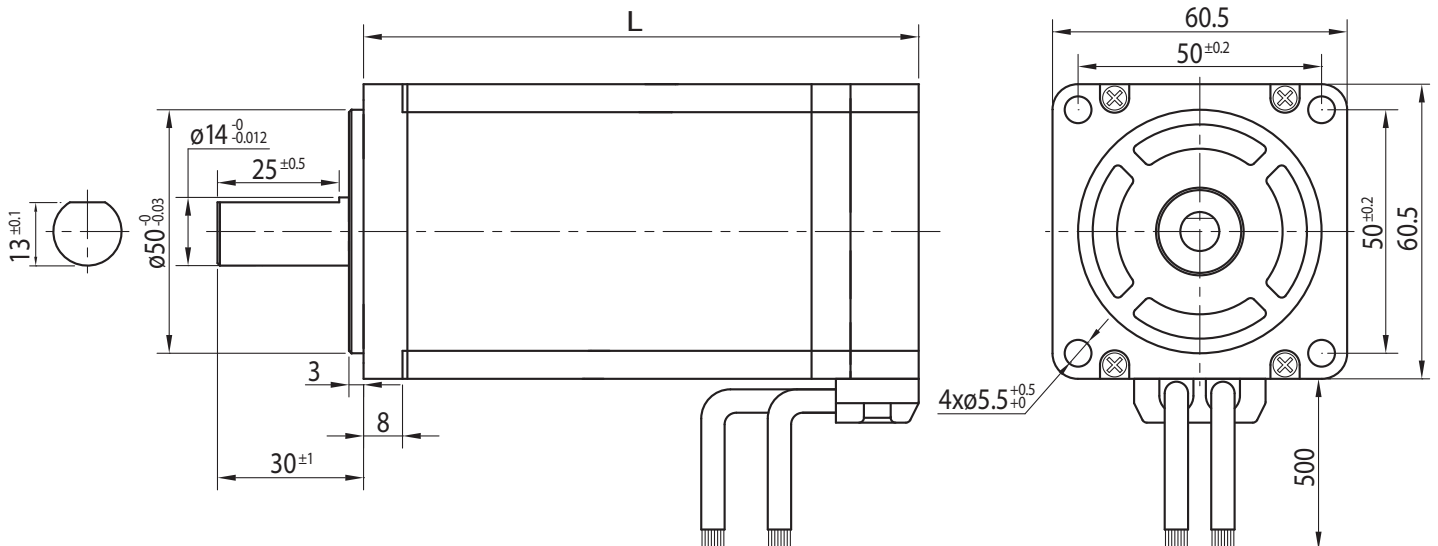
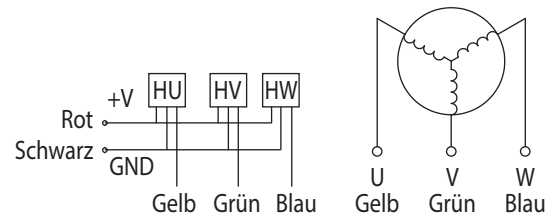

## Optionen

Encoder	Sonderwelle
B-seitige Welle	Sonderspannung
Anschlusstecker	Isolierklasse F/H