

BLDC-Motor Typ BL80S



Technische Daten

Modell	BL80.109-48S	BL80.109-220S	BL80.129-220S
Nennspannung (V)	48	220	220
Nenn Drehzahl (min ⁻¹)	3000	3000	3000
Nennmoment (Ncm)	160	160	239
Nennleistung (W)	500	500	750
Nennstrom (A)	14	3.3	5.0
Spitzenstrom (A)	42	10	15
Spitzendrehmoment (Ncm)	480	480	710
Rotorträgheitsmoment (gcm ²)	1600	1600	2100
Drehmomentkonstante (Ncm/A)	11	51	51
Gegen-EMK (V/min ⁻¹)	10.47	40	42
Widerstand (Ω)	1	3	2.2
Induktanz (mH)	0.9	6	9
Länge (mm)	109	109	129
Gewicht (kg)	2.04	2.2	3.2
Pole	8		
Phasen	3		
Isolierklasse	B		

Rel. Luftfeuchtigkeit: 20 bis 85% | Umgebungstemp.: -20 bis +50 °C

Anschlüsse

UL1007 AWG26	
Rot	Vcc
Gelb	Ha
Grün	Hb
Blau	Hc
Schwarz	GND

UL3266 AWG18	
Gelb	U
Grün	V
Blau	W

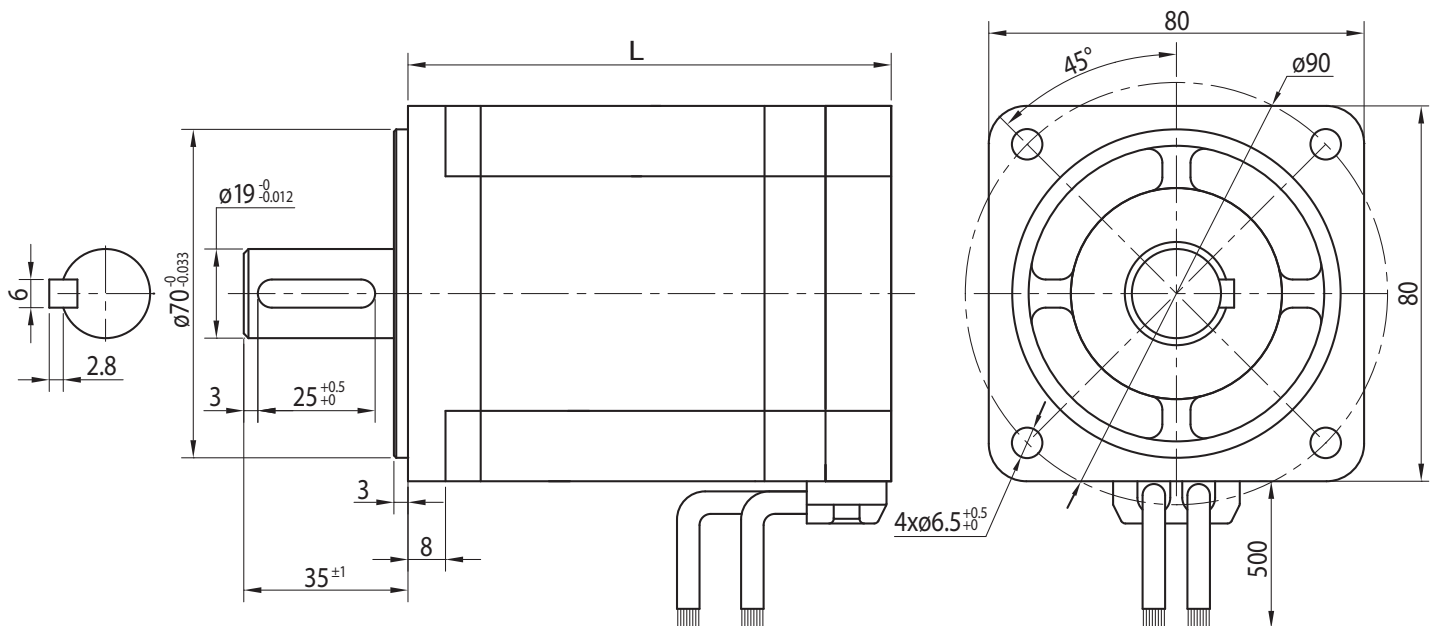
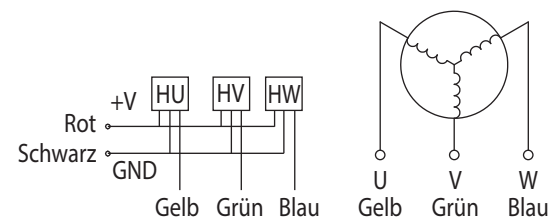

Optionen

Encoder	Sonderwelle
B-seitige Welle	Sonderspannung
Anschlusstecker	Isolierklasse F/H