

BLDC-Motor Typ BL86S



Technische Daten

Modell	BL86.54S	BL86.67S	BL86.81S	BL86.94S	BL86.121S
Nennspannung (V)	24	48	48	48	48
Nenn Drehzahl (min ⁻¹)	3000	3000	3000	3000	3000
Nennmoment (Ncm)	35	70	100	140	200
Nennleistung (W)	110	220	310	440	620
Nennstrom (A)	6.5	5.8	8.6	12	17.2
Spitzenstrom (A)	19.5	17.4	25.8	36	51.6
Spitzendrehmoment (Ncm)	105	210	300	420	600
Rotorträgheitsmoment (gcm ²)	1000	1600	1900	2100	2000
Drehmomentkonstante (Ncm/A)	5	12	11	12	11
Gegen-EMK (V/min ⁻¹)	4.5	11	10.5	11	10
Widerstand (Ω)	0.4	0.6	0.5	0.4	0.5
Induktanz (mH)	0.4	0.5	0.4	0.3	0.5
Länge (mm)	54	66.5	80.5	93.5	121
Gewicht (kg)	1.2	1.8	2.2	2.6	3.2
Pole	8				
Phasen	3				
Isolierklasse	B				

Rel. Luftfeuchtigkeit: 20 bis 85% | Umgebungstemp.: -20 bis +50 °C

Anschlüsse

UL1007 AWG26	
Rot	Vcc
Gelb	Ha
Grün	Hb
Blau	Hc
Schwarz	GND

UL3266 AWG18	
Gelb	U
Grün	V
Blau	W

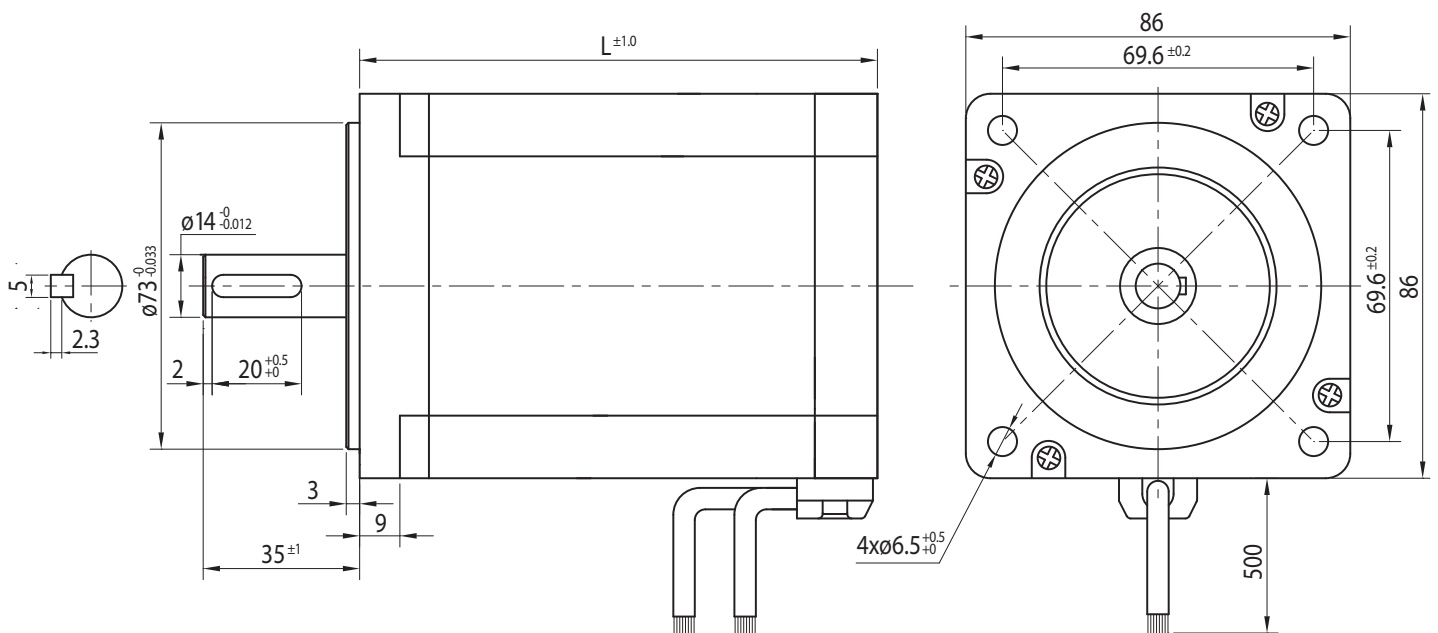
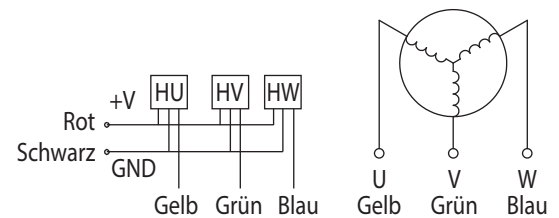

Optionen

Encoder	Sonderwelle
B-seitige Welle	Sonderspannung
Anschlusstecker	Isolierklasse F/H