

Schrittmotor Stirnradgetriebe Typ ST37-SH35.21-B



Getriebe

Untersetzungsverhältnis	6~10	18~30	36~100	120~300	350~1000	1500~3000
Länge L (mm)	19.5	22	24.5	27	29.5	32

Relative Luftfeuchtigkeit 20 bis 85% | Umgebungtemp.: -10 bis +60°C | Nettogewicht max. 197g

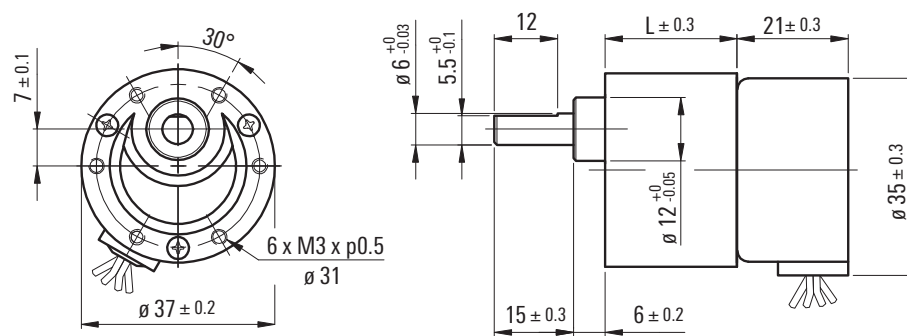

Optionen

Litzen
Anschlussstecker
Sonderwelle

Motor

Nennspannung (V)	Wicklungswiderstand (Ω)	Strom pro Phase (mA)	Anzahl der Phasen	Antriebssystem	Schrittinkel	Haltedrehmoment (Ncm)	Rastmoment (Ncm)
12	65	180	4	Bi-Polar	7.5°	5.8	≤1.5
24	120	200	4	Bi-Polar	7.5°	5.8	≤1.5

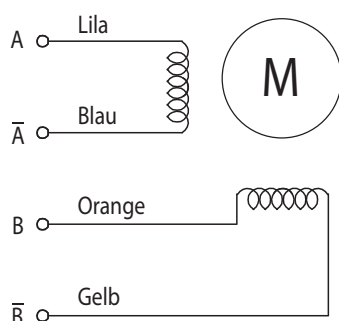
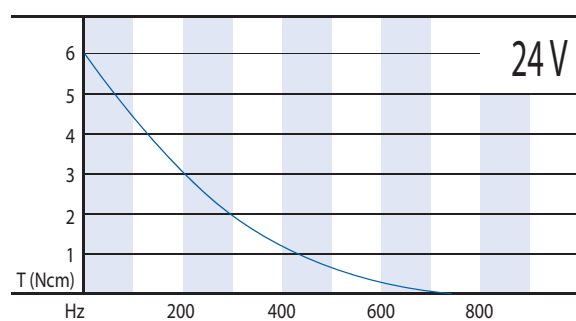
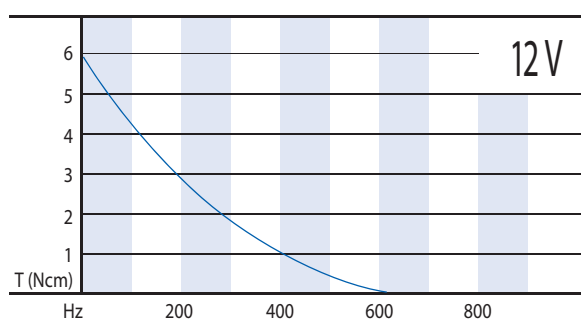

	Kabelfarbe	1	2	3	4	5	6	7	8
A	Lila	+	-	-	+	+	-	-	+
Ā	Blau	-	+	+	-	-	+	+	-
B	Orange	+	+	-	-	+	+	-	-
B̄	Gelb	-	-	+	+	-	-	+	+