

# BLDC Motor Planetary Gearbox Type PL22.10-BL22.45



## Gearmotor

Gear Ratio	3.7	5.2	14	19	27	51	71	100	139	189	264	369
No Load Speed (min <sup>-1</sup> )	1887	1351	500	368	259	137	99	70	50	37	27	19
Rated Speed (min <sup>-1</sup> )	1240	888	329	242	170	90	65	46	33	24	17	12
Rated Torque (Ncm)	2.7	3.7	9.1	12	17	30	41	58	80	100	100	100
Peak Torque (Ncm)	30	30	120	120	120	250	250	250	250	300	300	300
No. of Stages	1	1	2	2	2	3	3	3	3	4	4	4
Length L (mm)	24.4	24.4	33	33	33	41.5	41.5	41.5	41.5	49.8	49.8	49.8

Rel. Humidity: 20 to 85% | Ambient Temp.: -10 to +60 °C

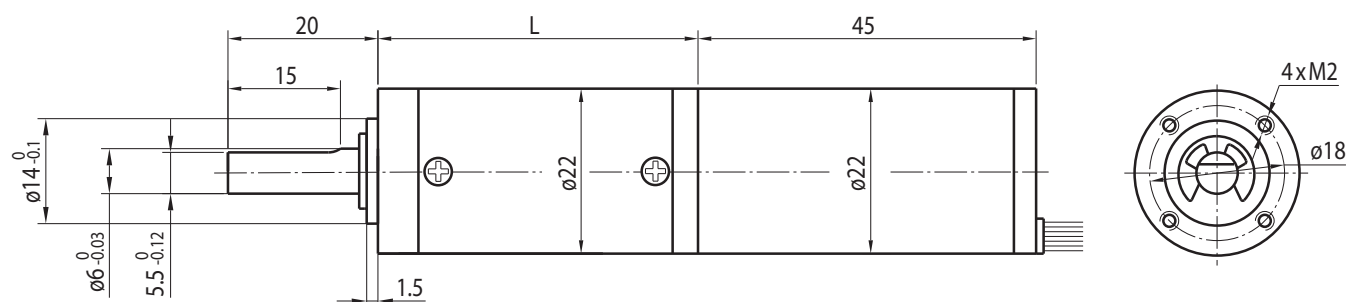

## Motor

No. of Poles	No. of Phases	Rated Voltage (V)	No Load Speed (min <sup>-1</sup> )	Rated Speed (min <sup>-1</sup> )	Rated Torque (Ncm)	Peak Torque (Ncm)	Peak Current (A)	Rated Power (W)
8	3	24	7000	4600	0.8	2.1	1.1	3.8

Radial Load (FR): 20 N (10 mm from face mounting) | Axial Load (FA): 10 N

## Connections

UL1007 AWG26	
Green	U
Red	V
Black	W

UL1007 AWG28	
Yellow	Vcc (+5 to +24V)
Blue	Ha
Orange	Hb
Brown	Hc
White	GND

## Options

Encoder
Rear Shaft
Connector
Special Shaft
Special Voltage

## Ball Bearing