

Stepping Motor Spur Gearbox Type ST37-SH35.21-B



Gearbox

Gear Ratio	6~10	18~30	36~100	120~300	350~1000	1500~3000
Length L (mm)	19.5	22	24.5	27	29.5	32

Rel. Humidity: 20 to 85% | Ambient Temp.: -10 to +60°C | Net Weight max. 197g

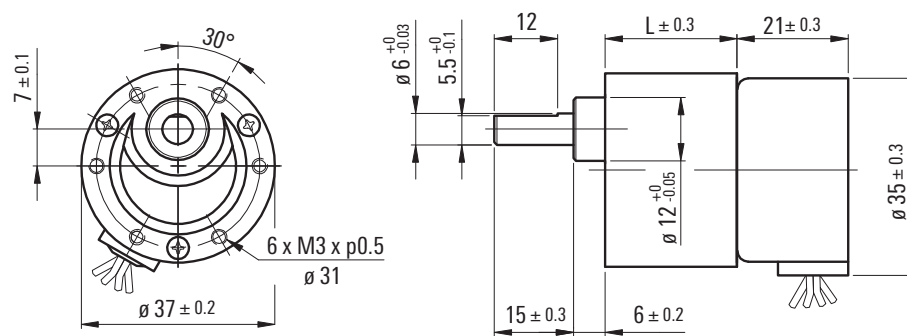

Options

Leads
Connector
Special Shaft

Motor

Rated Voltage (V)	Winding Resistance (Ω)	Current per Phase (mA)	Number of Phase	Drive System	Step Angle	Holding Torque (Ncm)	Detent Torque (Ncm)
12	65	180	4	Bi-Polar	7.5°	5.8	≤ 1.5
24	120	200	4	Bi-Polar	7.5°	5.8	≤ 1.5

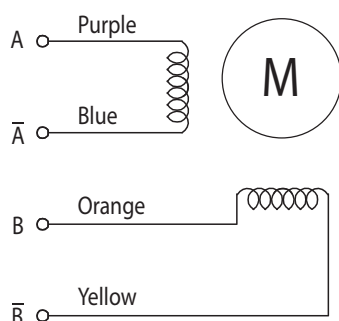
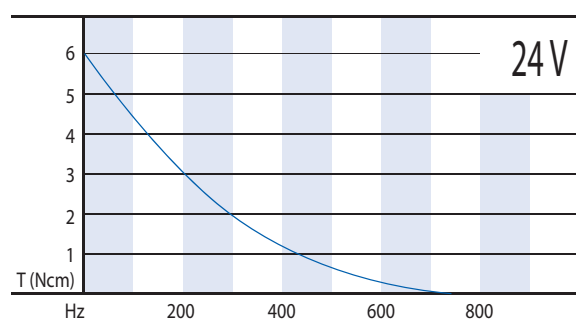
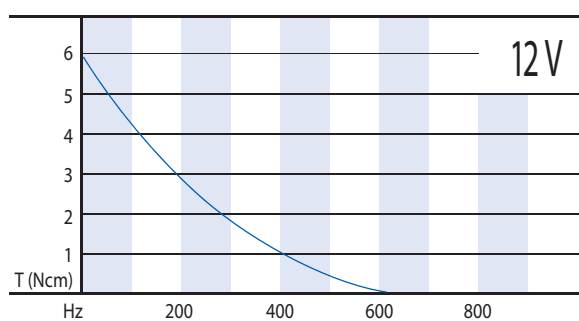

	Wire Color	1	2	3	4	5	6	7	8
A	Purple	+	-	-	+	+	-	-	+
Ā	Blue	-	+	+	-	-	+	+	-
B	Orange	+	+	-	-	+	+	-	-
B̄	Yellow	-	-	+	+	-	-	+	+