

DC-Motor Typ DC42



Technische Daten

Modell	DC42.80	DC42.90	DC42.100
Nennspannung (V)	24	24	24
Leerlaufdrehzahl (min ⁻¹)	4000	4000	4000
Nennmoment (Ncm)	3	5	7
Nenn-drehzahl (min ⁻¹)	3480	3350	3350
Nennstrom (A)	0.64	1.1	1.4
Blockiermoment (Ncm)	22	30	40
Blockierstrom (A)	4.2	5.6	7.5
Rotorträgheit (Kgmm ²)	11.6	15.4	19.3
Back-EMF (V/min ⁻¹)	5.84	5.84	5.84
Drehmomentkonstante (Ncm/A)	5.58	5.58	5.58
Widerstand (Ω)	5.8	4.1	3.2
Nettogewicht (g)	300	400	500
Länge L1 (mm)	80	90	100

Isolierklasse B | Umgebungtemp.: -10 bis +40 °C

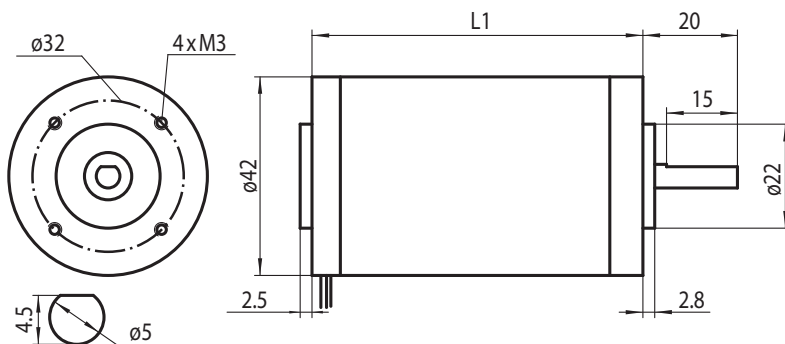

DC42.80

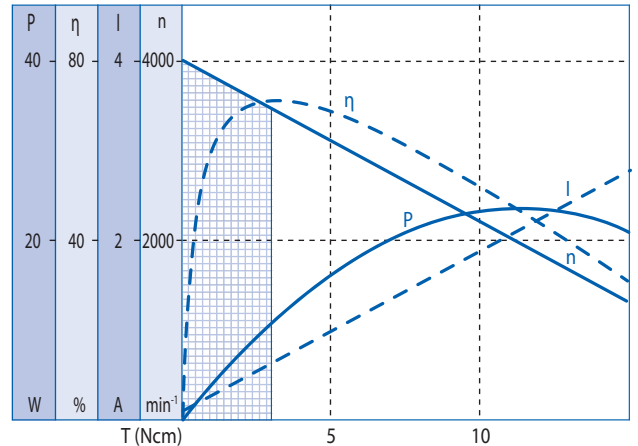

DC42.90

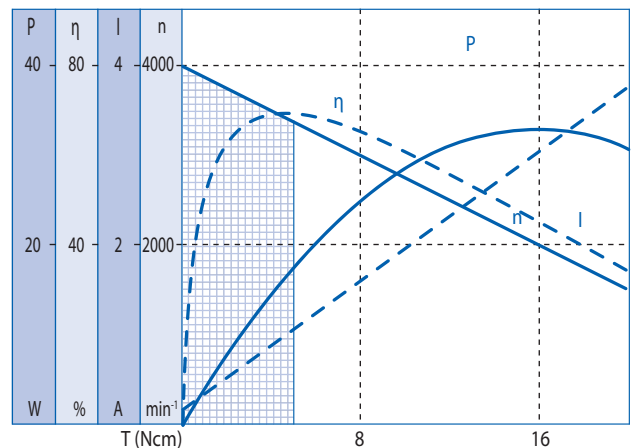

DC42.100

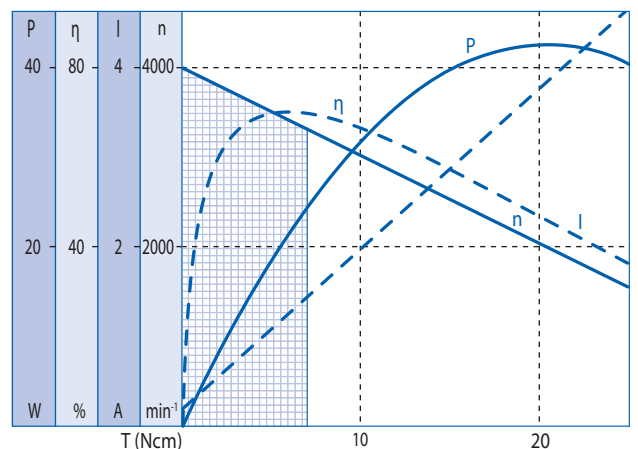

Optionen

Encoder	Bremse
B-seitige Welle	Sonderwelle
Entstörungsfilter	Sonderspannung
Kabel	Isolierklasse F/H
Anschlussstecker	Erhöhte Schutzart

Kugellager