

DC-Motor Typ DC52



Technische Daten

Modell	DC52.90	DC52.105	DC52.120
Nennspannung (V)	24	24	24
Leerlaufdrehzahl (min ⁻¹)	4000	4000	4000
Nennmoment (Ncm)	5	9	14
Nenn-drehzahl (min ⁻¹)	3400	3400	3400
Nennstrom (A)	1.1	1.92	2.9
Blockiermoment (Ncm)	33	61	93
Blockierstrom (A)	6.3	11.5	17.2
Rotorträgheit (Kgmm ²)	25	40	55
Back-EMF (V/min ⁻¹)	5.8	5.83	5.86
Drehmomentkonstante (Ncm/A)	5.54	5.57	5.6
Widerstand (Ω)	3.8	2.1	1.4
Nettogewicht (g)	700	950	1200
Länge L1 (mm)	90	105	120

Isolierklasse B | Umgebungstemp.: -10 bis +40 °C

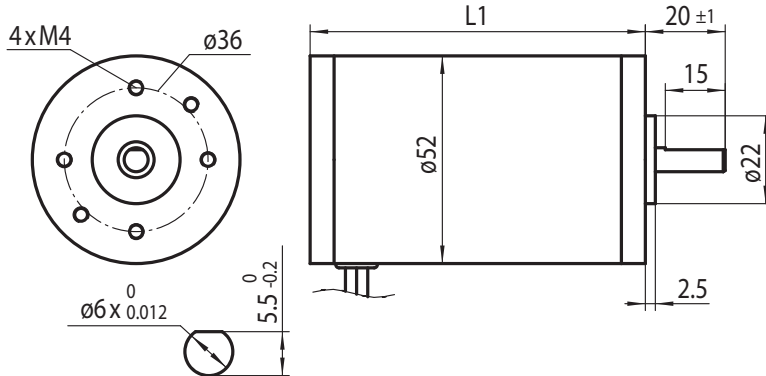

DC52.90

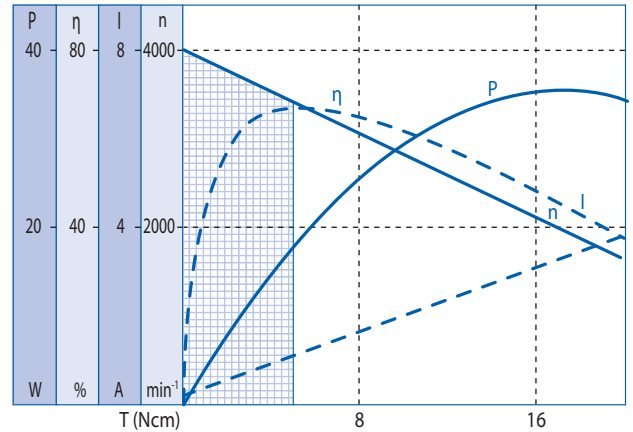

DC52.105

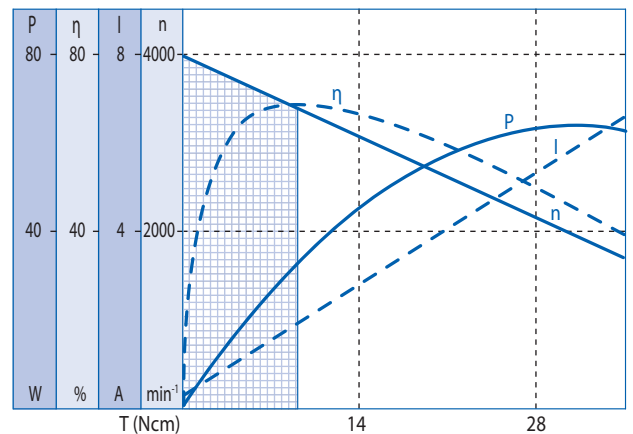

DC52.120

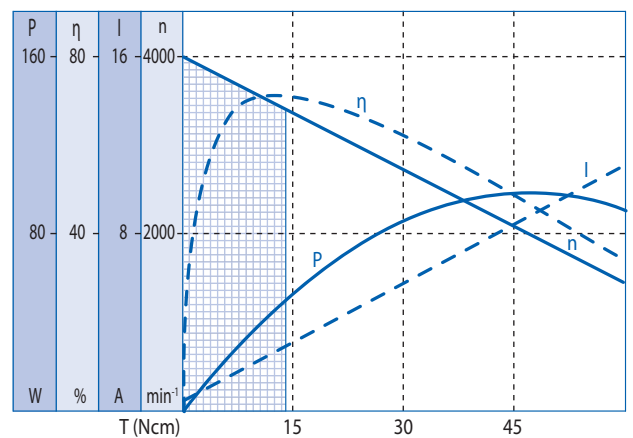

Optionen

Encoder	Bremse
B-seitige Welle	Sonderwelle
Entstörungfilter	Sonderspannung
Kabel	Isolierklasse F/H
Anschlussstecker	Erhöhte Schutzart

Kugellager