

DC-Motor Planetengetriebe Typ PL22C-DC22.31H



Getriebemotor

Untersetzungsverhältnis	5	18	20	25	66	77	90	110	136	246	336	393	484	597	735	1079	1475	2124	3968
12V	Nennmoment (Ncm)	1.7	5.6	6.5	8.2	18	21	24.5	30	37	50	50	50	50	50	60	60	60	60
	Nennndrehzahl (min ⁻¹)	1500	400	340	280	105	94	80	65	53	29	22	19	16	13	10	7	5	4
24V	Nennmoment (Ncm)	1.9	6.4	7.5	9.3	20	24	28	35	40	50	50	50	50	50	60	60	60	60
	Nennndrehzahl (min ⁻¹)	1600	420	350	290	110	98	84	68	55	31	23	20	16	13	11	7	6	4
Länge L (mm)	53.8	60.0	60.0	60.0	66.2	66.2	66.2	66.2	66.2	72.4	72.4	72.4	72.4	72.4	72.4	78.6	78.6	78.6	78.6

Rel. Luftfeuchtigkeit: 20 bis 85% | Umgebungstemp.: -10 bis +60°C | Nettogewicht max. 115g

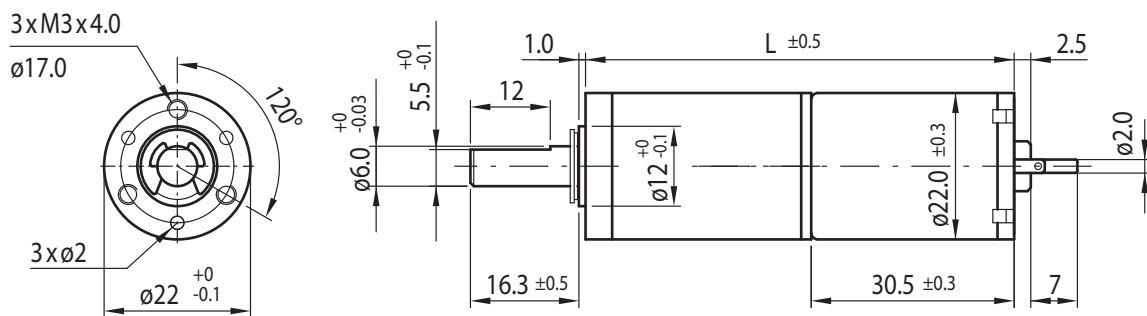

Optionen

Encoder
Entstörungsfilter
Litzen
Anschlusstecker
Sonderwelle
Sonderspannung



Motor

Nennspannung (V)	Nennmoment (Ncm)	Nennndrehzahl (min ⁻¹)	Nennstrom (mA)	Leerlaufndrehzahl (min ⁻¹)	Leerlaufstrom (mA)	Nennleistung (W)
12	0.46	7230	≤500	9000	≤120	3.41
24	0.53	7550	≤300	9000	≤80	4.11

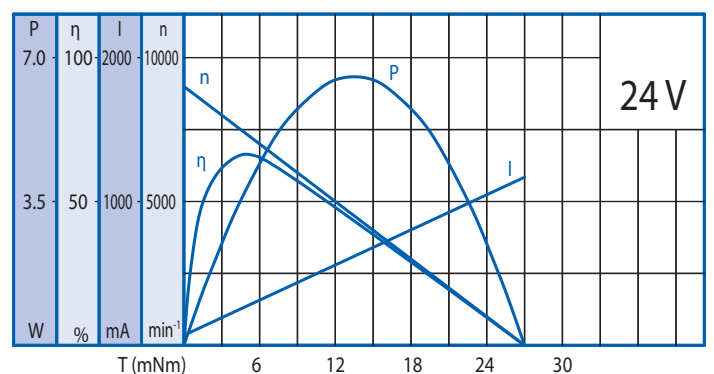
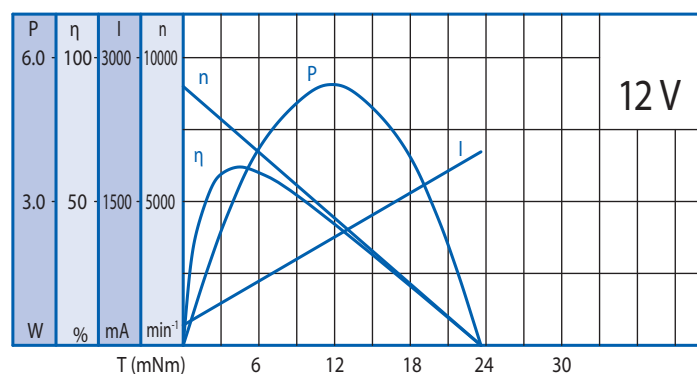

Getriebe

Untersetzungsverhältnis	5	18	20	25	66	77	90	110	136	246	336	393	484	597	735	1079	1475	2124	3968
Dauerrehmoment, max. (Ncm)	10	30	30	30	40	40	40	40	40	50	50	50	50	50	50	60	60	60	60
Spitzenrehmoment, max. (Ncm)	30	90	90	90	120	120	120	120	120	150	150	150	150	150	150	180	180	180	180

Kugellager

Radiallast (FR): 12 N (10 mm v. Flansch) | Axiallast (FA): 7 N