

DC-Motor Planetengetriebe Typ PL36-DC36.65



Getriebemotor

Untersetzungsverhältnis	5	14	19	27	51	71	100	139	189	264	516	721
12V	Nennmoment (Ncm)	11	25	36	50	82	115	160	200	250	300	300
	Nennndrehzahl (min ⁻¹)	1250	475	340	243	129	92	66	47	35	25	13
24V	Nennmoment (Ncm)	11	27	38	53	87	120	170	200	250	300	300
	Nennndrehzahl (min ⁻¹)	1240	470	335	240	127	91	65	47	34	25	13
Länge L (mm)		98.1	106.8	106.8	106.8	115.5	115.5	115.5	115.5	124.2	124.2	124.2

Rel. Luftfeuchtigkeit: 20 bis 85% | Umgebungstemp.: -10 bis +60°C | Nettogewicht max. 476g

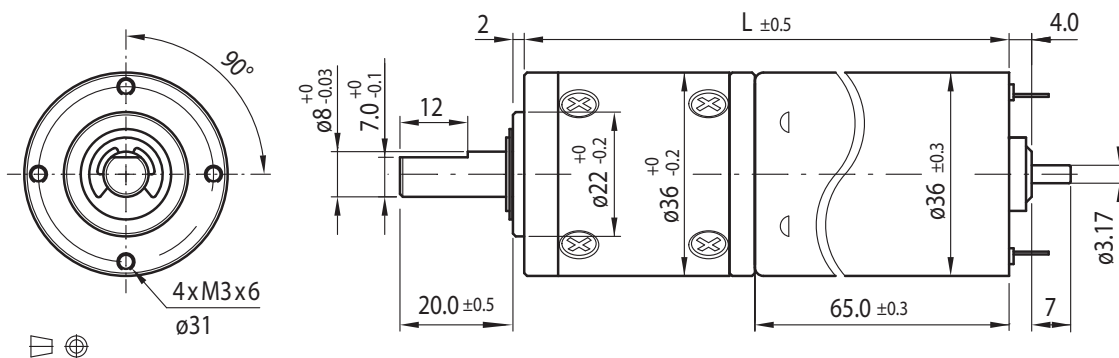

Optionen

Encoder
Entstörungsfilter
Litzen
Anschlusstecker
Sonderwelle
Sonderspannung

Motor

Nennspannung (V)	Nennmoment (Ncm)	Nennndrehzahl (min ⁻¹)	Nennstrom (mA)	Leerlaufdrehzahl (min ⁻¹)	Leerlaufstrom (mA)	Nennleistung (W)
12	2.7	6570	≤ 2050	7500	≤ 300	18.23
24	2.85	6480	≤ 1050	7500	≤ 210	18.96

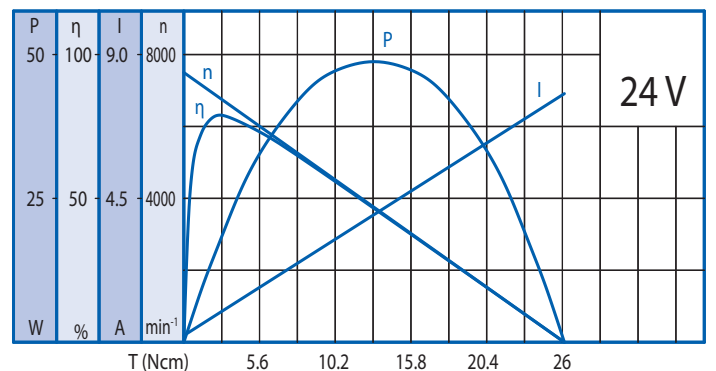
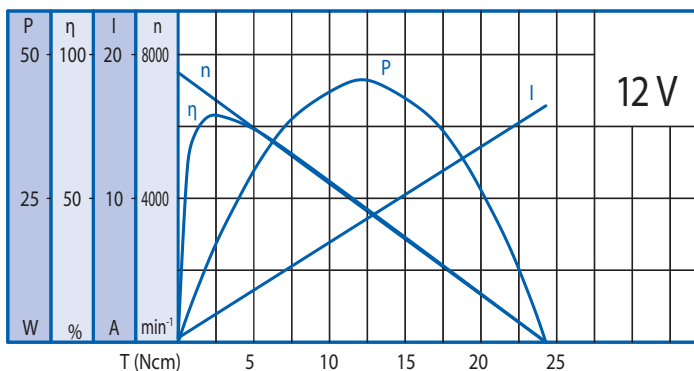

Getriebe

Untersetzungsverhältnis	5	14	19	27	51	71	100	139	189	264	516	721
Dauerdrehmoment, max. (Ncm)	30	80	80	100	180	180	200	200	250	250	300	300
Spitzendrehmoment, max. (Ncm)	90	240	240	300	540	540	600	600	750	750	900	900

Kugellager

Radiallast (FR): 80 N (10 mm v. Flansch) | Axiallast (FA): 30 N