

# BLDC Motor Planetary Gearbox Type PL56.200-BL57.79

PowerTronic



## Gearmotor

Gear Ratio	3.6	4.25	13	15	18	32	47	55	65	76	
BL57.79-24.20	No Load Speed (min <sup>-1</sup> )	556	471	154	133	111	63	43	36	31	26
	Rated Speed (min <sup>-1</sup> )	333	282	92	80	67	38	26	22	18	16
	Rated Torque (Ncm)	1	1.1	3.2	3.6	4.4	7.8	10	12	14	17
	Peak Torque (Ncm)	6	6	25	25	25	25	50	50	50	50
BL57.79-24.30	No Load Speed (min <sup>-1</sup> )	833	706	231	200	167	94	64	55	46	39
	Rated Speed (min <sup>-1</sup> )	556	471	154	133	111	63	43	36	31	26
	Rated Torque (Ncm)	1	1.1	3.2	3.6	4.4	7.8	10	12	14	17
	Peak Torque (Ncm)	6	6	25	25	25	25	50	50	50	50
No. of Stages	1	1	2	2	2	2	3	3	3	3	
Length L (mm)	118.5	118.5	130.5	130.5	130.5	130.5	141.5	141.5	141.5	141.5	

Radial Load (FR): 250 N (10 mm from face mounting) | Axial Load (FA): 100 N

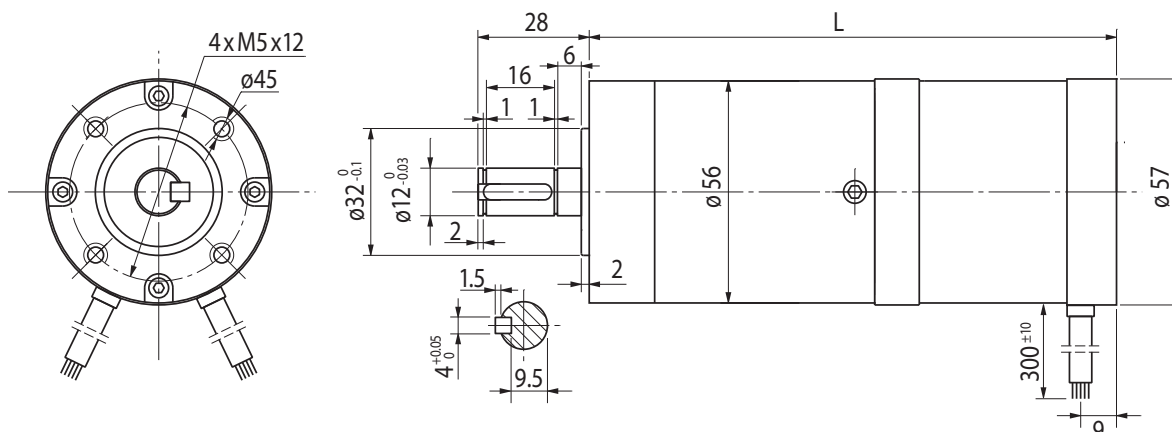

## Motor

Model	BL57.79-24.20	BL57.79-24.30
Rated Voltage (V)	24	24
Rated Speed (min <sup>-1</sup> )	1200	2000
Rated Torque (mNm)	300	300
Rated Current (A)	2.8	4
No Load Current (mA)	≤ 450	≤ 400
No Load Speed (min <sup>-1</sup> )	2000	3000
Rated Power (W)	40	60

Rel. Humidity: 20 to 85% | Ambient Temp.: -10 to +60 °C

## Connections

UL1430 AWG26	
Red	+5V bis +24V
Blue	Ha
Green	Hb
White	Hc
Black	GND

UL1430 AWG20	
Yellow	U
Red	V
Black	W

## Options

Encoder
Rear Shaft
Connector
Special Shaft
Special Voltage

## Ball Bearing