

# BLDC Motor Planetary Gearbox Type PL42-BL42.62

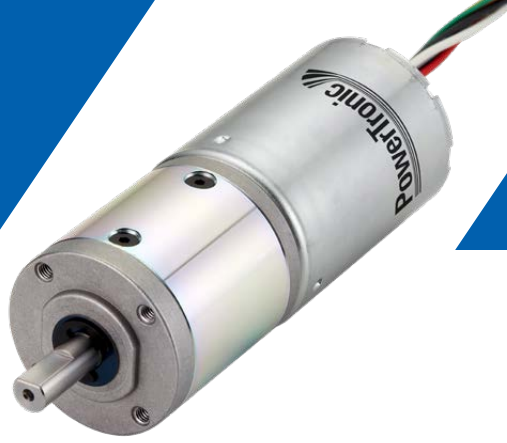

## Gearmotor

| Gear Ratio    | 4                                | 14   | 17  | 24  | 49   | 61  | 84  | 104 | 144  | 212 | 294 | 504 | 624 | 720  | 864 | 1062 | 1470 | 2500 | 3000 | 3600 |     |
|---------------|----------------------------------|------|-----|-----|------|-----|-----|-----|------|-----|-----|-----|-----|------|-----|------|------|------|------|------|-----|
| 24V           | Rated Torque (Ncm)               | 27   | 80  | 80  | 80   | 180 | 180 | 180 | 200  | 200 | 250 | 250 | 300 | 300  | 300 | 300  | 300  | 300  | 300  | 300  | 300 |
|               | Rated Speed (min <sup>-1</sup> ) | 1125 | 325 | 270 | 200  | 95  | 75  | 55  | 45   | 35  | 24  | 17  | 10  | 8.4  | 7.3 | 6    | 5    | 3.5  | 2.1  | 1.7  | 1.4 |
| Length L (mm) | 32.5                             | 39.2 |     |     | 45.9 |     |     |     | 52.6 |     |     |     |     | 59.6 |     |      |      |      |      |      |     |

Rel. Humidity: 20 to 85% | Ambient Temp.: -10 to +60°C | Net Weight max. 693g

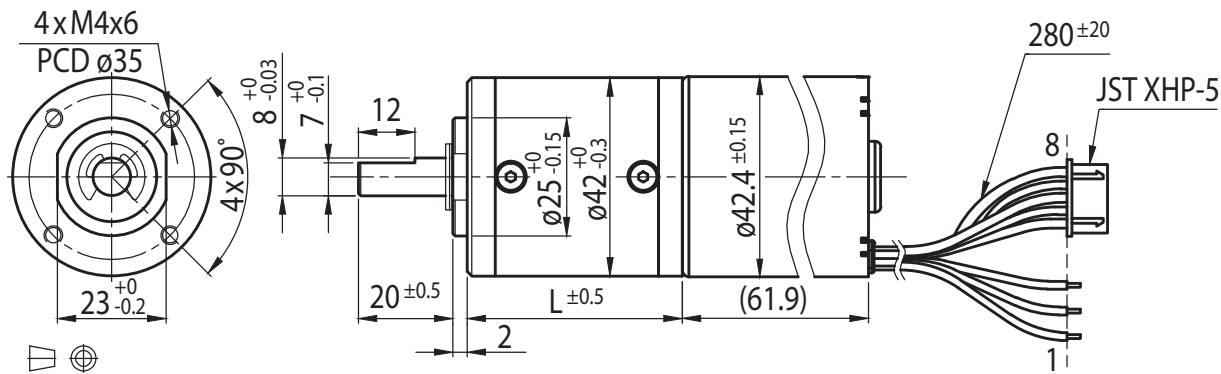

## Motor

| Rated Voltage (V) | Rated Torque (Ncm) | Rated Speed (min <sup>-1</sup> ) | Rated Current (A) | No Load Speed (min <sup>-1</sup> ) | No Load Current (A) | Rated Power (W) |
|-------------------|--------------------|----------------------------------|-------------------|------------------------------------|---------------------|-----------------|
| 24                | 8.7                | 4500                             | ≤2.3              | 5400                               | ≤0.4                | 40              |

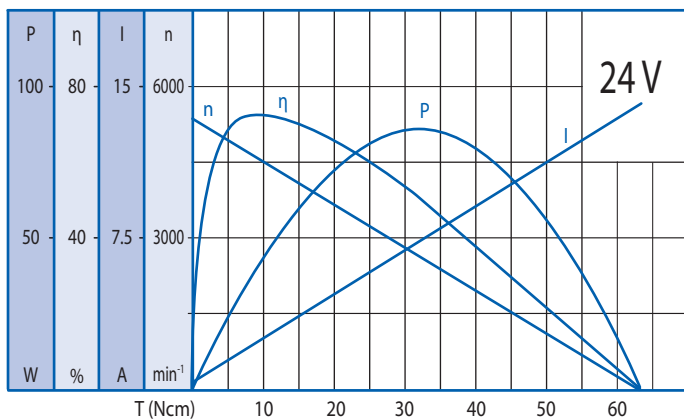

## Connections

| Pin No | Colour | Function | Wire Spec       |
|--------|--------|----------|-----------------|
| 1      | Red    | U        | UL1430<br>18AWG |
| 2      | Black  | V        |                 |
| 3      | White  | W        |                 |
| 4      | Blue   | GND      | UL1430<br>26AWG |
| 5      | Yellow | HU       |                 |
| 6      | Brown  | HV       |                 |
| 7      | Gray   | HW       |                 |
| 8      | Green  | +5V      |                 |

Ball Bearing

Radial Load (FR): 80N (10mm from face mounting) | Axial Load (FA): 30N