

DC-Motor Typ DC22.38



Technische Daten

Modell	Nennspannung (V)	Leerlaufdrehzahl (min ⁻¹)	Leerlaufstrom (A)	Nennzahl (min ⁻¹)	Nennstrom (A)	Nennmoment (Ncm)	Nennleistung (W)	Wirkungsgrad (%)	Blockierstrom (A)	Blockiermoment (Ncm)
08590	24.0	4000	0.038	3067	0.088	0.34	1.1	54	0.31	1.6
12310	24.0	7500	0.080	5938	0.254	0.59	3.7	62	1.20	3.5
16210	12.0	5200	0.100	4474	0.337	0.54	2.5	66	1.55	3.0
19135	12.0	8500	0.150	7508	0.513	0.52	4.1	69	3.15	3.9

Umgebungstemp.: -10 bis +60 °C | Nettogewicht max. 50g

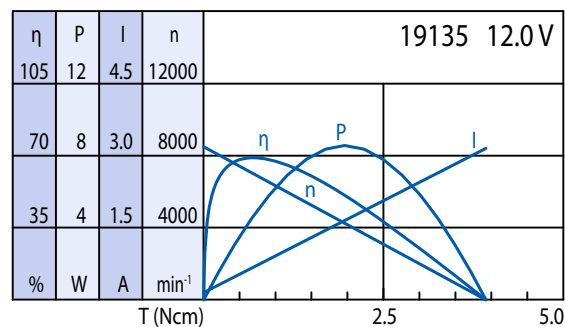
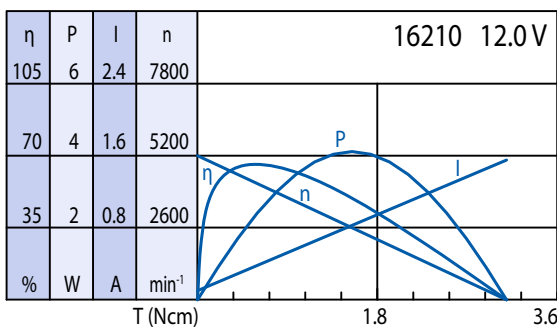
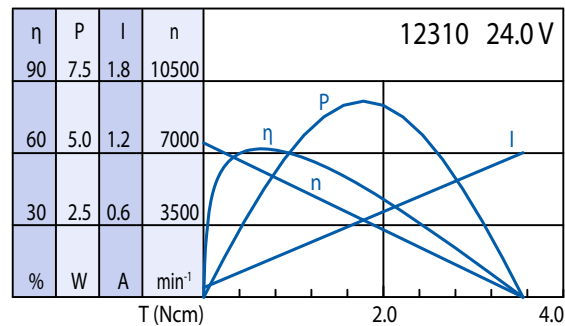
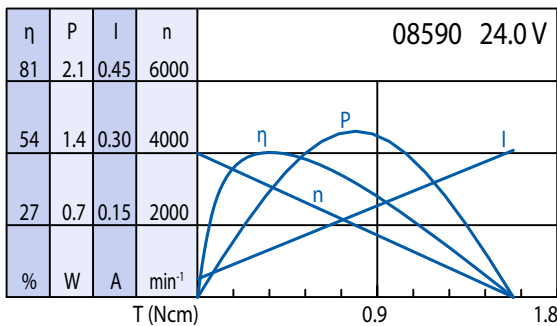
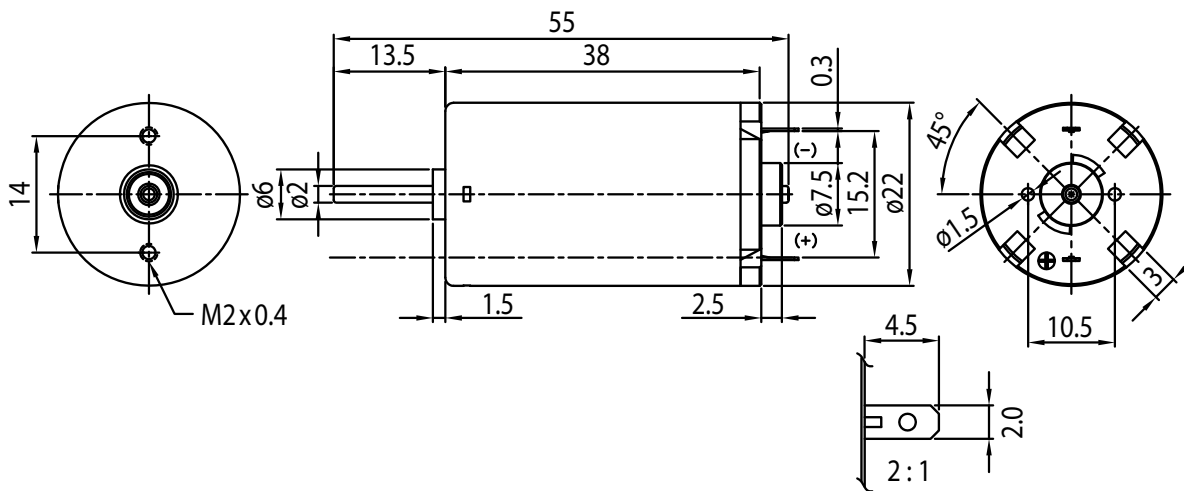

Optionen

Entstörungsfilter
Litzen
Anschlussstecker
Sonderwelle
Sonderspannung
Kugellager
Encoder