

BLDC-Motor mit integrierter Elektronik Typ BL24.18-IE

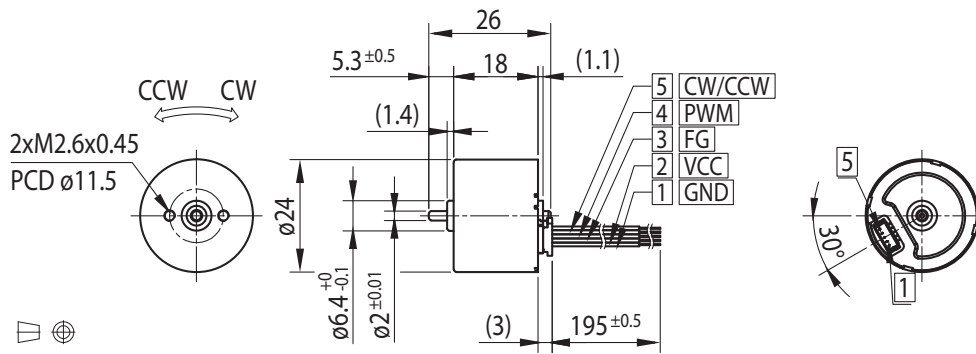
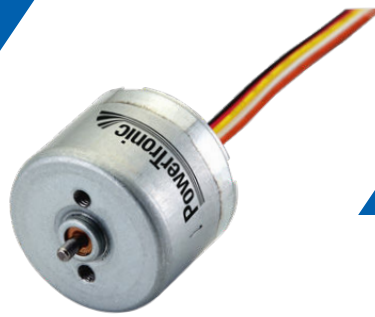

Pin-Nr.	Farbe	Funktion	Spezifikation der Leitung
1	Schwarz	GND	UL3302 28AWG
2	Rot	VCC	
3	Gelb	FG	
4	Weiß	PWM	
5	Orange	CW/CCW	

Motor

Nennspannung (V)	Nennmoment (Ncm)	Nenn Drehzahl (min^{-1})	Nennstrom (A)	Leerlaufdrehzahl (min^{-1})	Leerlaufstrom (A)	Nennleistung (W)	Max. Wirkungsgrad (%)	Gewicht (g)
12	0.3	5340	0.31	7400	0.18	1.65	46	28
24	0.28	6700	0.19	8700	0.14	1.93	48	28

